

1 WALK OVER POLE- BRIDGE

2 WALK OVERS

3 JOG OVERS

4 LL LOPE OVERS

5 LL LOPE TO GATE -STOP- LH OPEN GATE

WALK THRU CLOSE -JOG OUT

6 JOG OVERS

7 JOG INTO CHUTE STOP BACK -UP

U INTO CHUTE RL LOPE OUT

8 RL LOPE OVERS

9 BREAK TO A WALK DO NOT STOP - WALK IN BOX

360 TURN EITHER WAY-WALK OVERS

END OF PATTERN

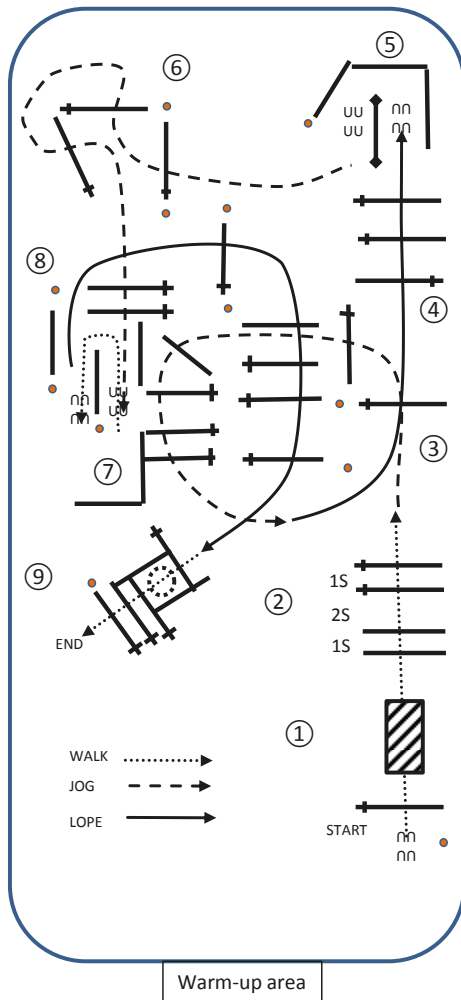

- 1 WALK OVERS
- 2 JOG OVERS
- 3 LL LOPE OVERS
- 4 LL LOPE TO GATE -STOP-LH OPEN GATE
WALK THRU CLOSE - JOG OUT
- 5 JOG OVERS
- 6 JOG INTO CHUTE STOP BACK -UP
U INTO CHUTE RL LOPE OUT
- 7 RL LOPE OVERS
- 8 BREAK TO A WALK DO NOT STOP - WALK IN BOX
360 TURN EITHER WAY-WALK OVERS
END OF PATTERN

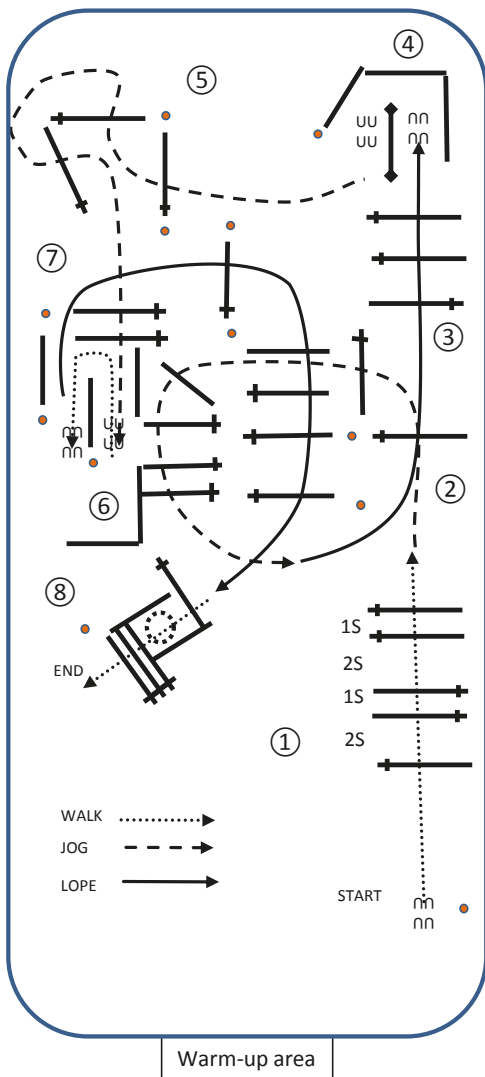

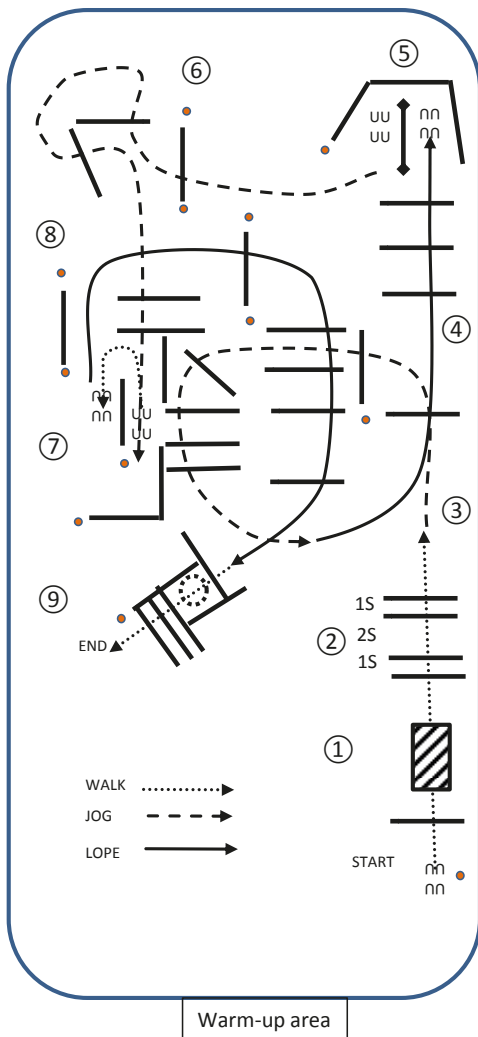

1 WALK OVER POLE- BRIDGE

2 WALK OVERS

3 JOG OVERS

4 LL LOPE OVERS

5 LL LOPE TO GATE -STOP- LH OPEN GATE

WALK THRU CLOSE -JOG OUT

6 JOG OVERS

7 JOG INTO CHUTE STOP **BACK -UP**

U INTO CHUTE RL LOPE OUT

8 RL LOPE OVERS

9 BREAK TO A WALK DO NOT STOP - WALK IN BOX

360 TURN EITHER WAY-WALK OVERS

END OF PATTERN

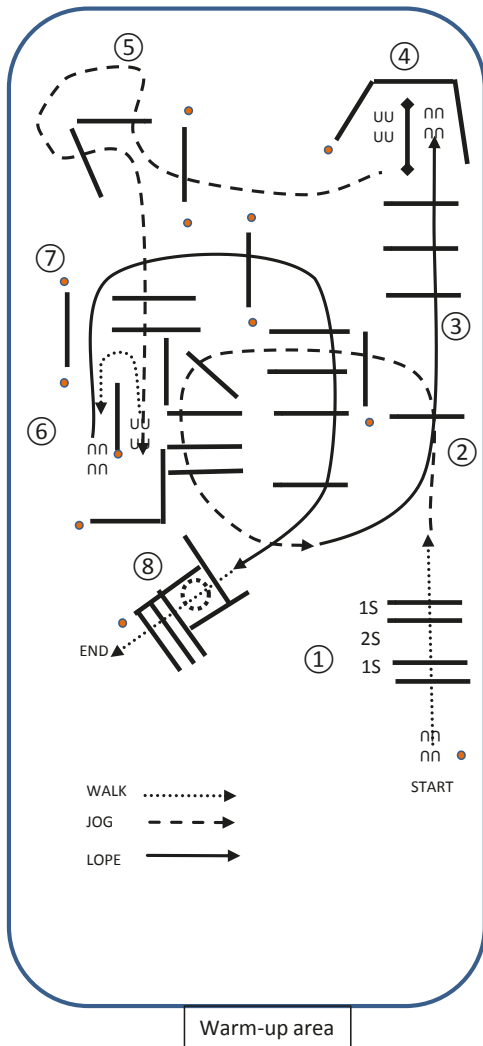

- 1 WALK OVERS
- 2 JOG OVERS
- 3 LL LOPE OVERS
- 4 LL LOPE TO GATE -STOP-LH OPEN GATE
WALK THRU CLOSE - JOG OUT
- 5 JOG OVERS
- 6 JOG INTO CHUTE STOP **BACK -UP**
U INTO CHUTE RL LOPE OUT
- 7 RL LOPE OVERS
- 8 BREAK TO A WALK DO NOT STOP - WALK IN BOX
360 TURN EITHER WAY-WALK OVERS
END OF PATTERN

LK 3 TRAIL

#5

01/2018

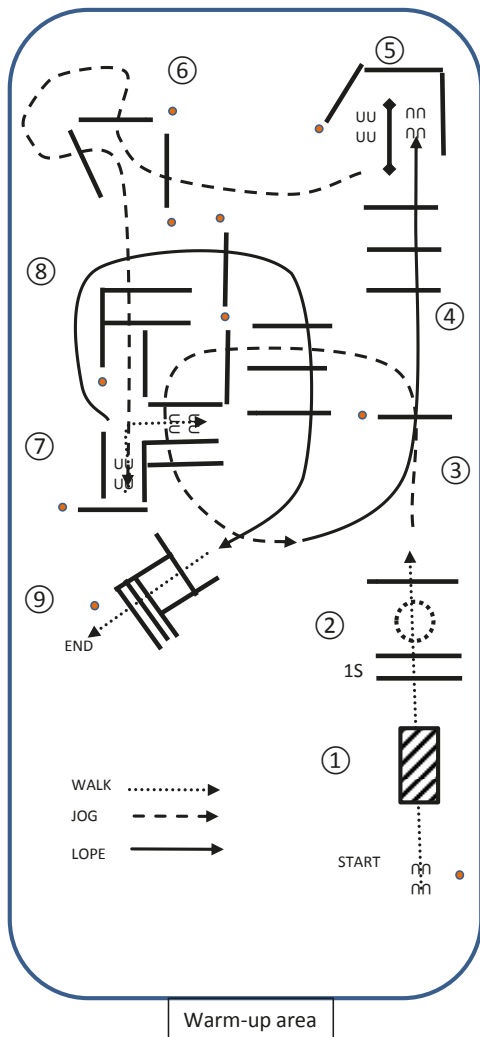

1 BRIDGE

2 WALK OVERS-360 EITHER WAY-WALK OVER

3 JOG OVERS

4 LL LOPE OVERS

5 LL LOPE TO GATE-STOP-LH OPEN GATE WALK
THRU CLOSE-JOG OUT

6 JOG OVERS

7 JOG INTO CHUTE STOP-BACK L INTO CHUTE
RL LOPE OUT

8 RL LOPE OVERS

9 BREAK TO A WALK OR STOP-WALK IN BOX
WALK OVERS

END OF PATTERN

LK 3 TRAIL

#6

01/2018

- 1 WALK OVERS
 - 2 360 EITHER WAY-WALK OVER
 - 3 JOG OVERS
 - 4 LL LOPE OVERS
 - 5 LL LOPE TO GATE-STOP-LH OPEN GATE WALK THRU CLOSE-JOG OUT
 - 6 JOG OVERS
 - 7JOG INTO CHUTE STOP-BACK L INTO CHUTE RL LOPE OUT
 - 8 RL LOPE OVERS
 - 9 BREAK TO A WALK OR STOP-WALK IN BOX WALK OVERS
- END OF PATTERN

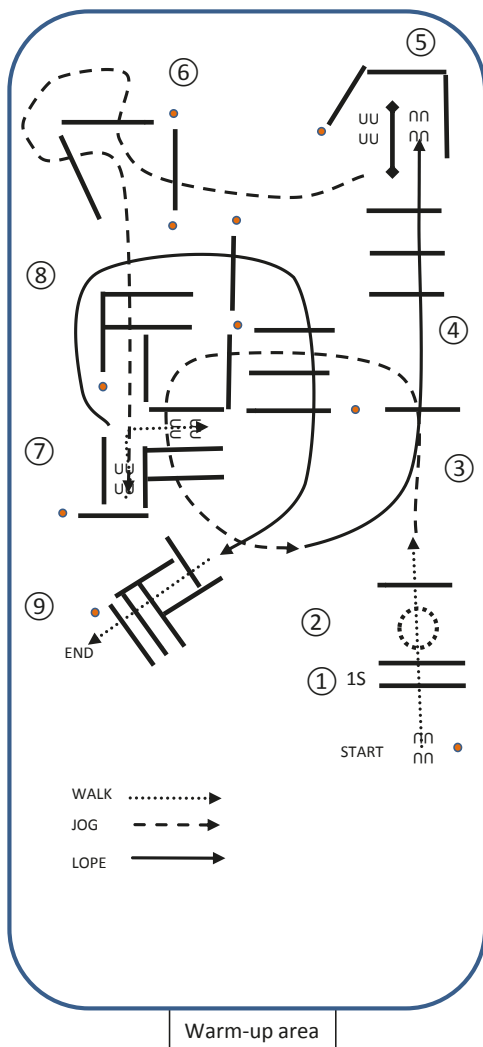

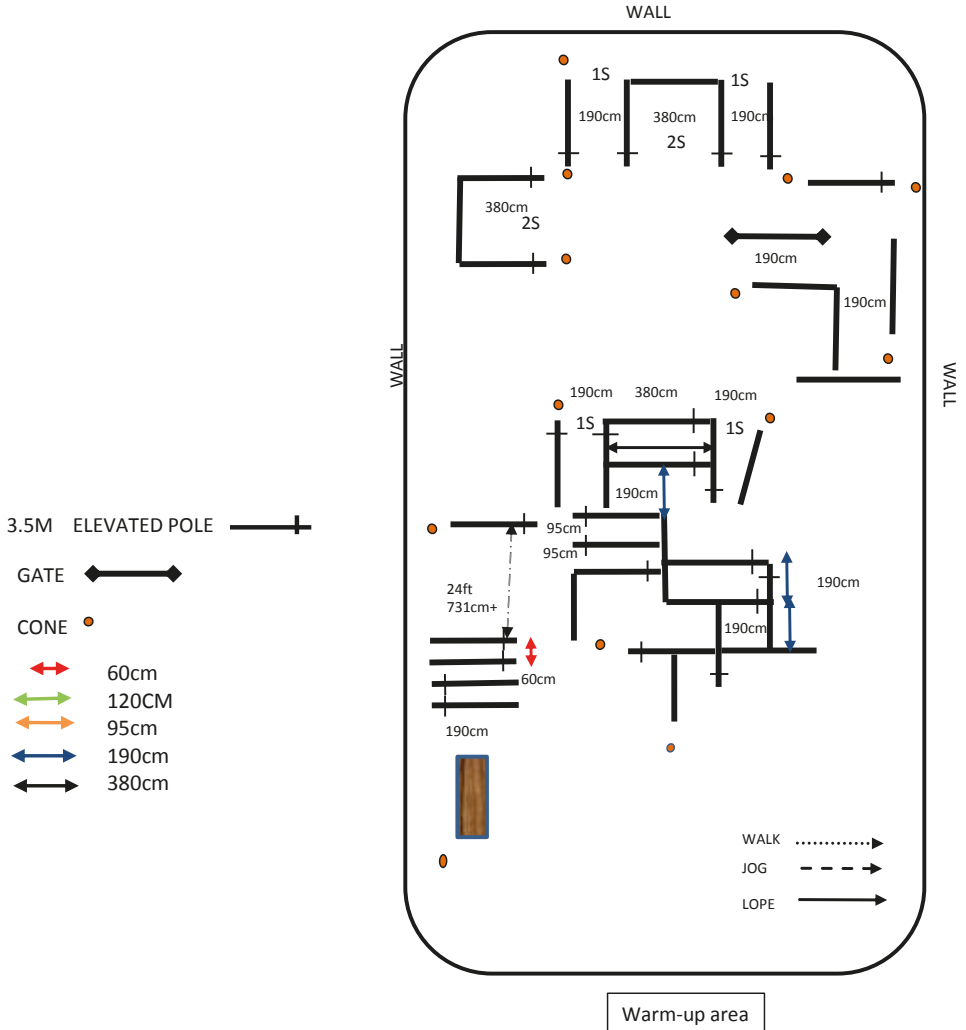

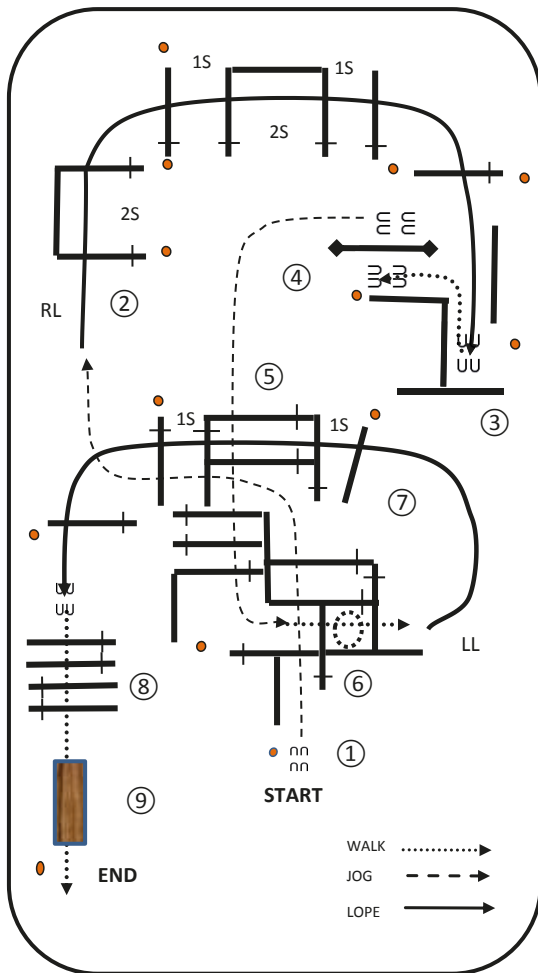

- 1 JOG OVERS
- 2 RL LOPE OVERS
- 3 LOPE INTO CHUTE STOP-BACK L TO GATE STOP
- 4 LH GATE OPEN RIDE THRU CLOSE-JOG OUT
- 5 JOG OVERS
- 6 STOP OR BREAK TO A WALK-WALK IN BOX 360 EITHER WAY-WALK OVER
- 7 LL LOPE OVERS
- 8 STOP OR BREAK TO A WALK-WALK OVERS
- 9 BRIDGE-END OF PATTERN

Warm-up area

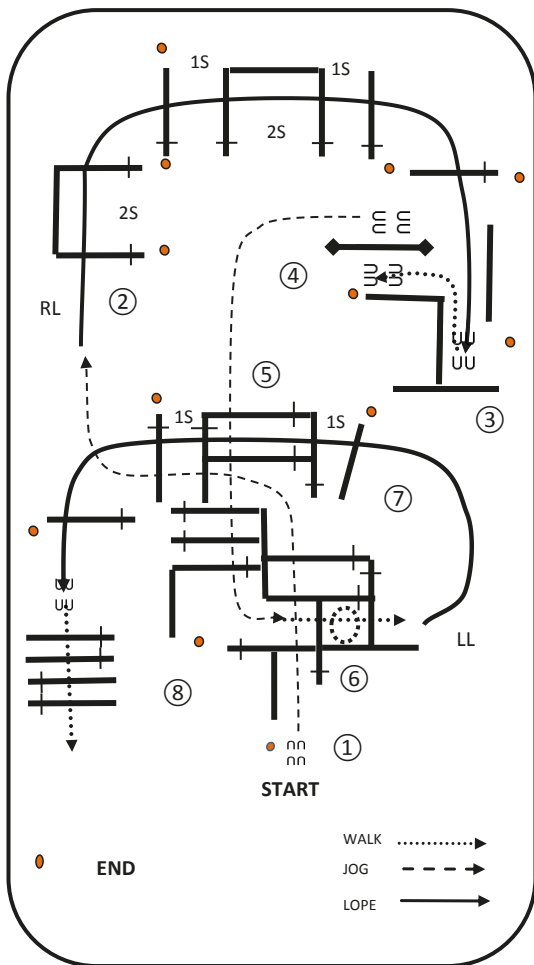

1 JOG OVERS

2 RL LOPE OVERS

3 LOPE INTO CHUTE STOP-BACK L TO GATE-STOP

4 LH GATE OPEN RIDE THRU CLOSE-JOG OUT

5 JOG OVERS

6 STOP OR BREAK TO A WALK-WALK IN BOX
360 EITHER WAY-WALK OVER

7 LL LOPE OVERS

8 STOP OR BREAK TO A WALK-WALK OVERS

END OF PATTERN

Warm-up area

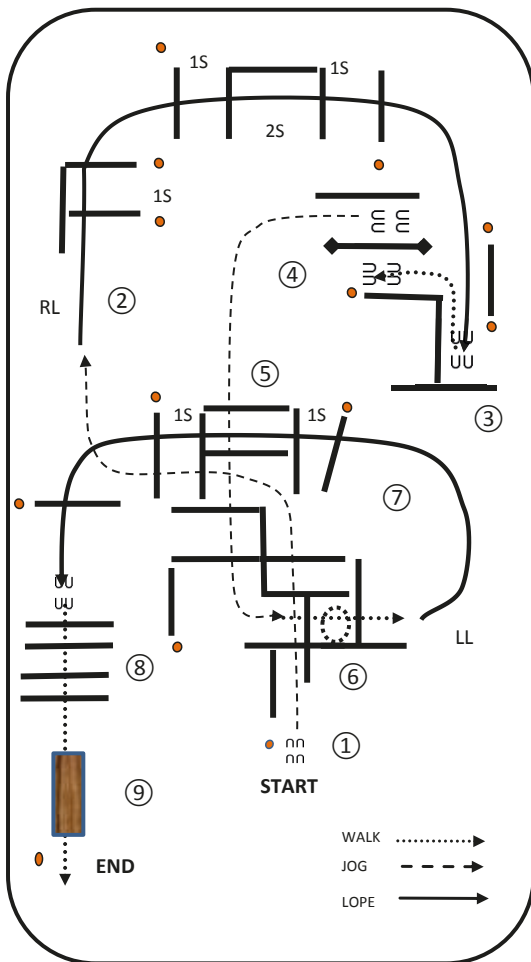

- 1 JOG OVERS
- 2 RL LOPE OVERS
- 3 LOPE INTO CHUTE STOP-BACK L TO GATE-STOP
- 4 LH GATE OPEN RIDE THRU CLOSE-JOG OUT
- 5 JOG OVERS
- 6 STOP OR BREAK TO A WALK-WALK IN BOX
360 EITHER WAY-WALK OVER
- 7 LL LOPE OVERS
- 8 STOP OR BREAK TO A WALK-WALK OVERS
- 9 BRIDGE-END OF PATTERN

Warm-up area

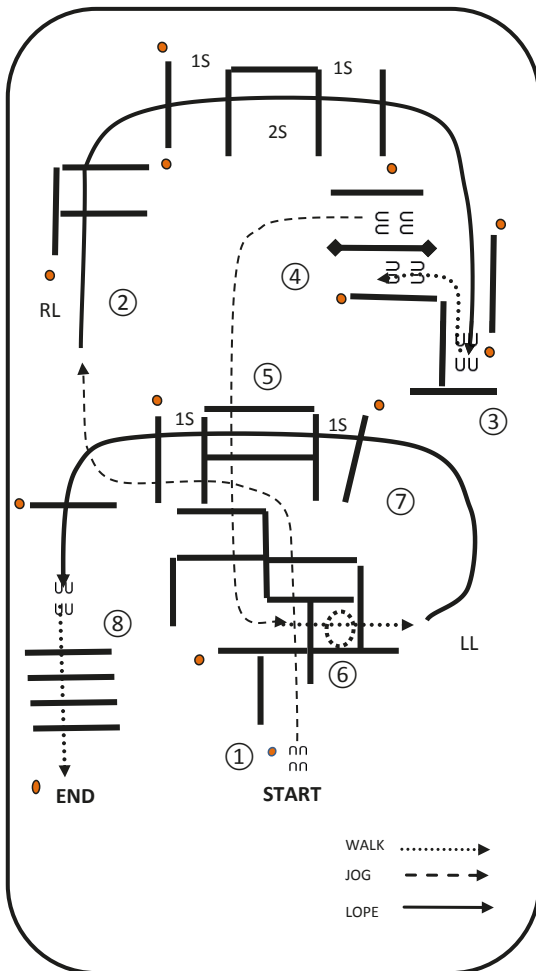

- 1 JOG OVERS
 - 2 RL LOPE OVERS
 - 3 LOPE INTO CHUTE STOP-BACK L TO GATE-STOP
 - 4 LH GATE OPEN RIDE THRU CLOSE-JOG OUT
 - 5 JOG OVERS
 - 6 STOP OR BREAK TO A WALK-WALK IN BOX
360 EITHER WAY-WALK OVER
 - 7 LL LOPE OVERS
 - 8 STOP OR BREAK TO A WALK-WALK OVERS
- END OF PATTERN

Warm-up area

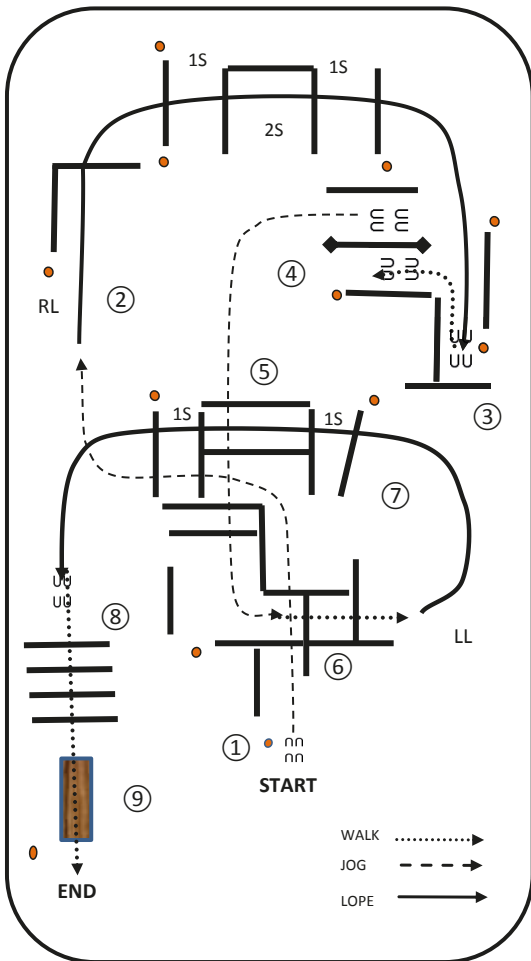

- 1 JOG OVERS
- 2 RL LOPE OVERS
- 3 LOPE INTO CHUTE STOP-BACK L TO GATE-STOP
- 4 LH GATE OPEN RIDE THRU CLOSE-JOG OUT
- 5 JOG OVERS
- 6 STOP OR BREAK TO A WALK-WALK OVERS
- 7 LL LOPE OVERS
- 8 STOP OR BREAK TO A WALK-WALK OVERS
- 9 BRIDGE END OF PATTERN

Warm-up area

LK 3 TRAIL

#12

01 / 01 / 2018

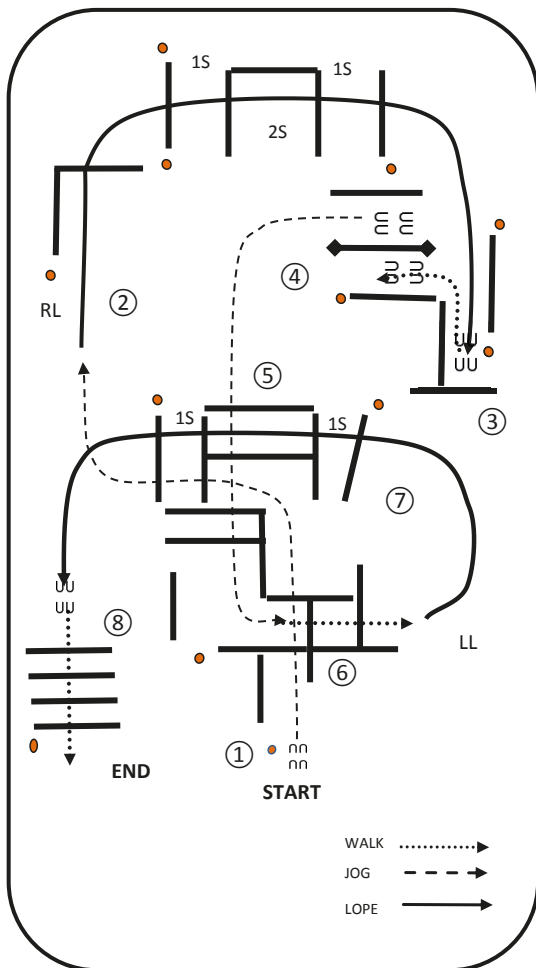

- 1 JOG OVERS
- 2 RL LOPE OVERS
- 3 LOPE INTO CHUTE STOP-BACK L TO GATE-STOP
- 4 LH GATE OPEN RIDE THRU CLOSE-JOG OUT
- 5 JOG OVERS
- 6 STOP OR BREAK TO A WALK-WALK OVERS
- 7 LL LOPE OVERS
- 8 STOP OR BREAK TO A WALK-WALK OVERS
- END OF PATTERN

Warm-up area

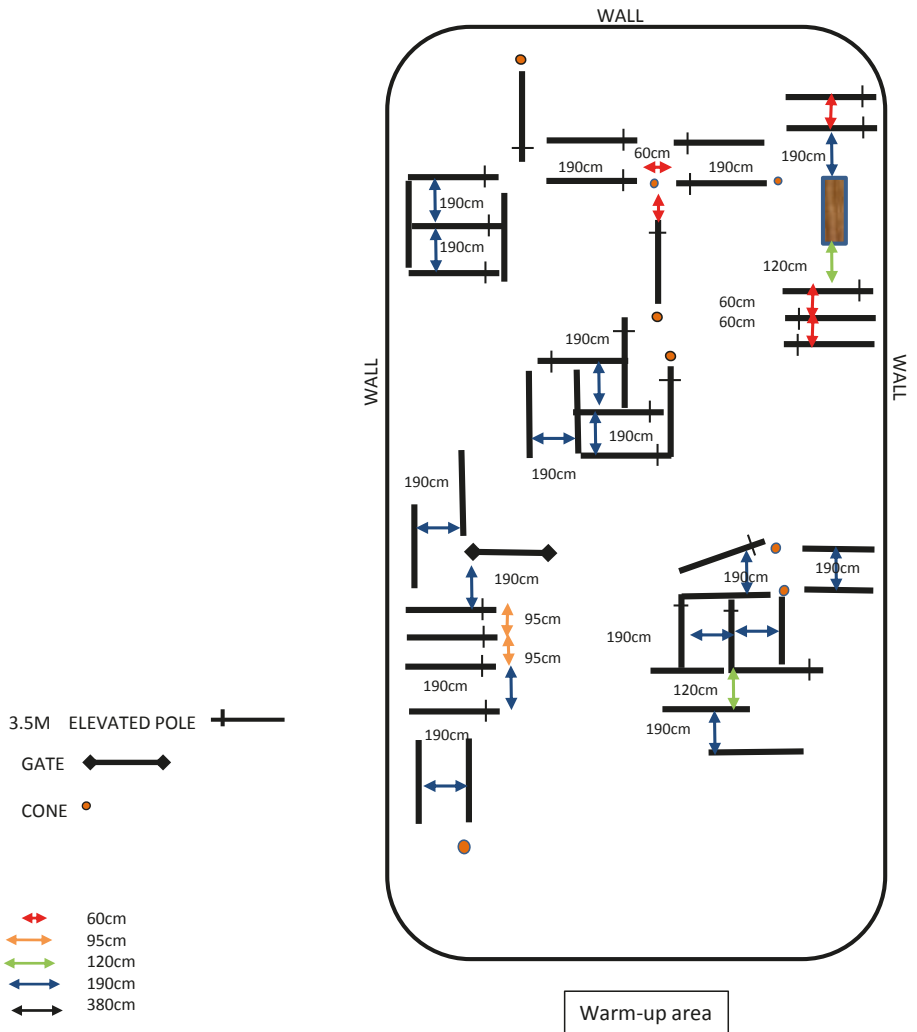

- 1 JOG OVERS INTO CHUTE
- 2 STOP IN CHUTE BACK TO GATE
- 3 RH GATE OPEN RIDE THRU CLOSE-JOG OUT
- 4 JOG OVERS
- 5 STOP OR BREAK TO A WALK-WALK OVERS-
BRIDGE--WALK OVERS
- 6 LL LOPE OVERS
- 7 JOG OVERS
- 8 RL LOPE OVERS
- 9 LOPE IN CHUTE-STOP OR BREAK TO A WALK
WALK OVER POLE-SIDEPASS 2ND POLE
END OF PATTERN

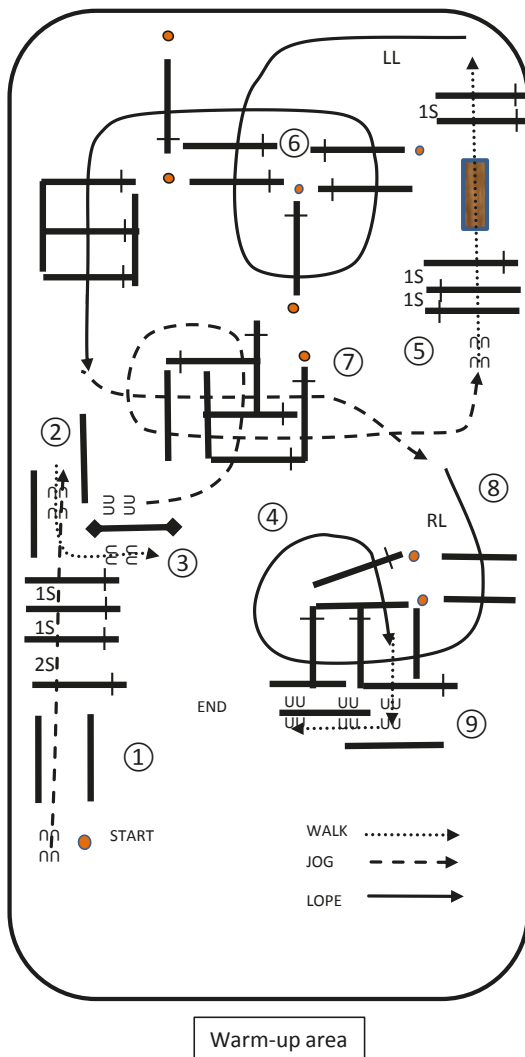

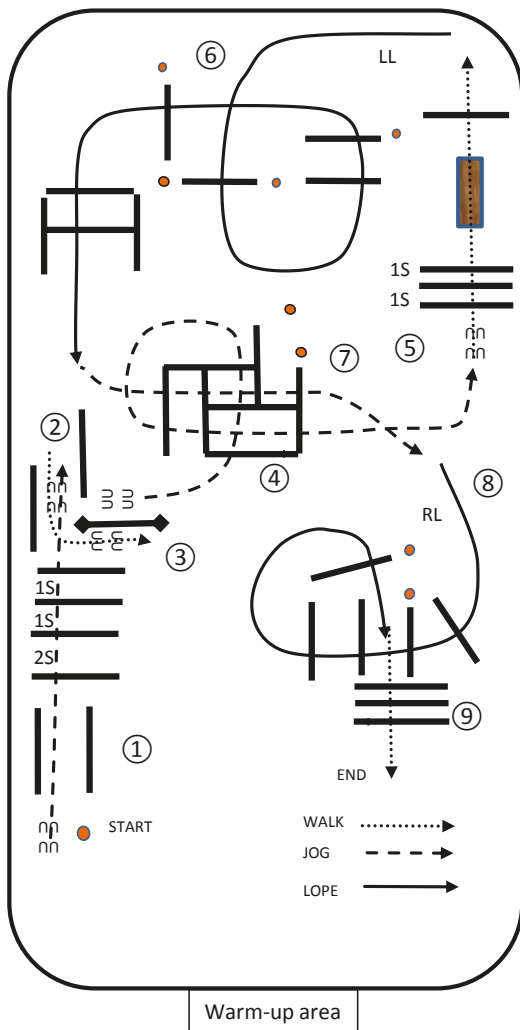

1 JOG OVERS INTO CHUTE

2 STOP IN CHUTE BACK TO GATE

3 RH GATE OPEN RIDE THRU CLOSE-JOG OUT

4 JOG OVERS

5 STOP OR BREAK TO A WALK-WALK OVERS-
BRIDGE-WALK OVERS

6 LL LOPE OVERS

7 JOG OVERS

8 RL LOPE OVERS

9 LOPE IN CHUTE-STOP OR BREAK TO A WALK
WALK OVERS
END OF PATTERN

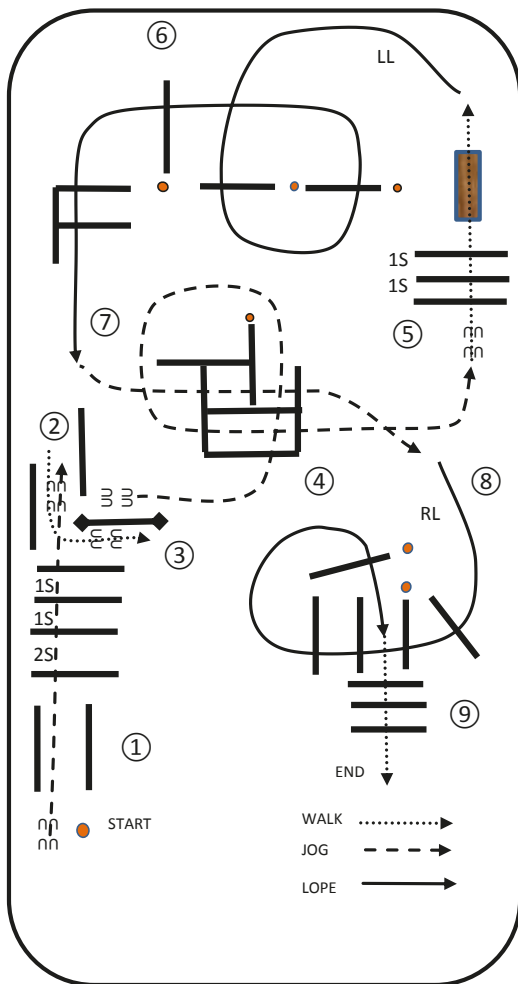

1 JOG OVERS INTO CHUTE

2 STOP IN CHUTE BACK TO GATE

3 RH GATE OPEN RIDE THRU CLOSE-JOG OUT

4 JOG OVERS

5 STOP OR BREAK TO A WALK-WALK OVERS-BRIDGE

6 LL LOPE OVERS

7 JOG OVERS

8 RL LOPE OVERS

9 LOPE IN CHUTE-STOP OR BREAK TO A WALK
WALK OVERS
END OF PATTERN

Warm-up area

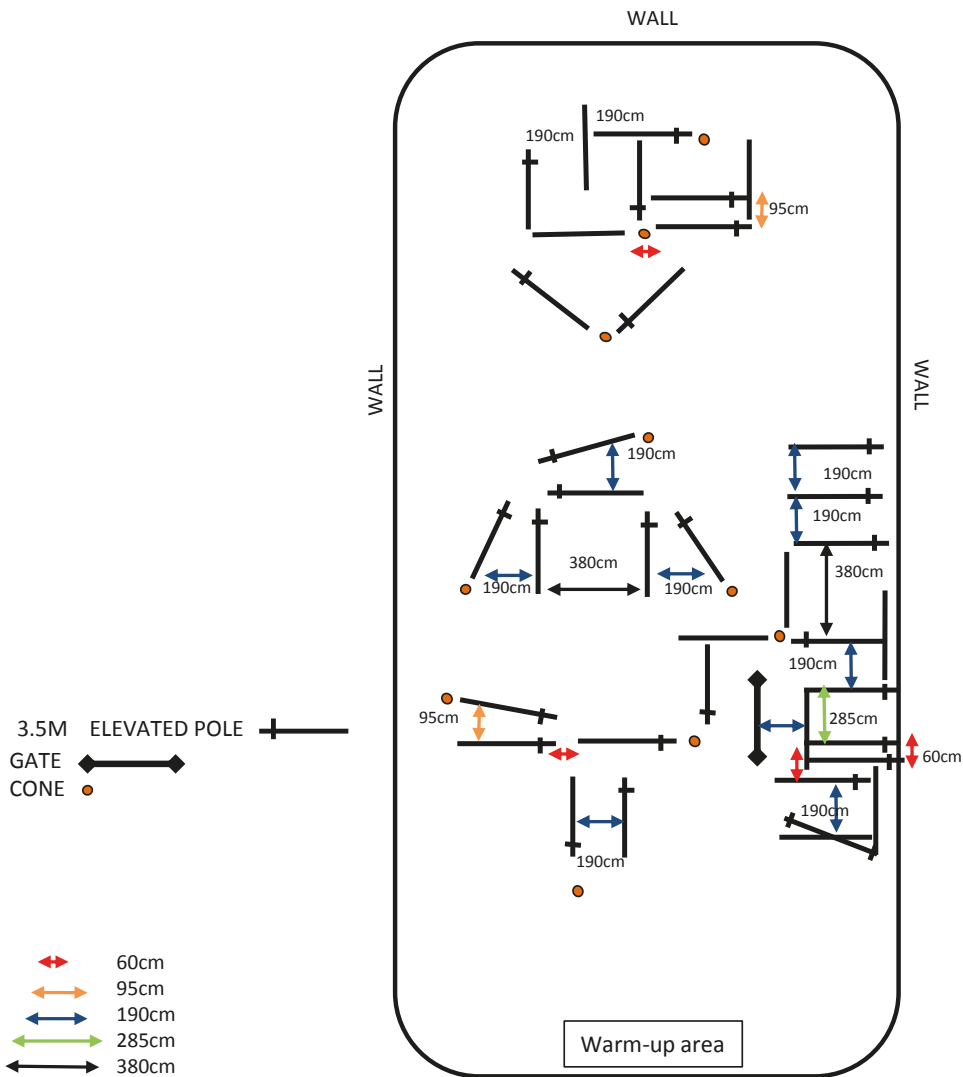

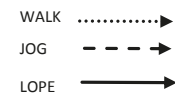

- 1 JOG OVERS PAST MARKER INTO CHUTE-STOP
 - 2 BACK TO GATE
 - 3 LH GATE OPEN RIDE THRU CLOSE-JOG OUT
 - 4 JOG OVERS
 - 5 LL LOPE OVERS
 - 6 JOG OVERS
 - 7 RL LOPE OVERS
 - 8 LOPE IN CHUTE-STOP-360 EITHER WAY
 - 9 WALK OVERS
- END OF PATTERN

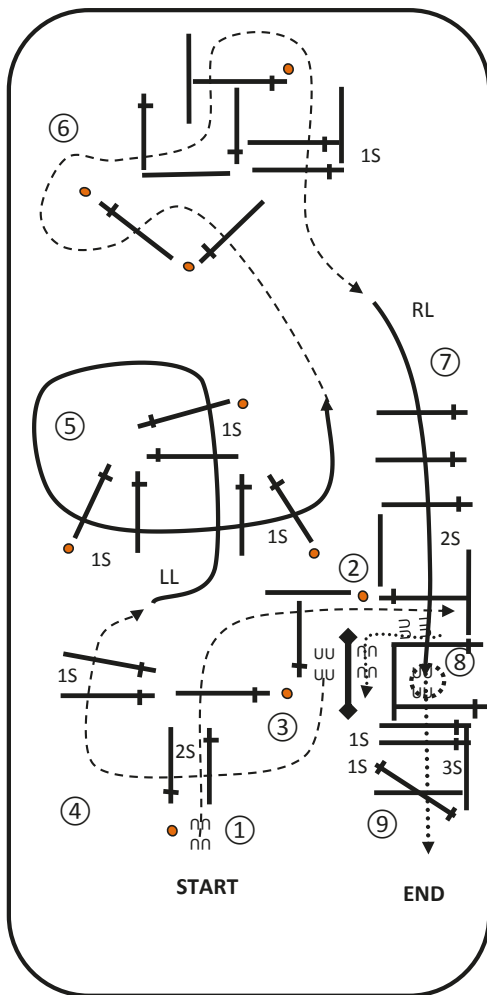

Warm-up area

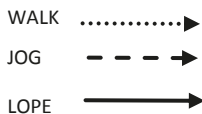

- 1 JOG OVERS PAST MARKER INTO CHUTE-STOP
- 2 BACK L TO GATE
- 3 LH GATE OPEN RIDE THRU CLOSE-JOG OUT
- 4 JOG OVERS
- 5 LL LOPE OVERS
- 6 JOG OVERS
- 7 RL LOPE OVERS
- 8 LOPE IN CHUTE-STOP-360 EITHER WAY
- 9 WALK OVERS
END OF PATTERN

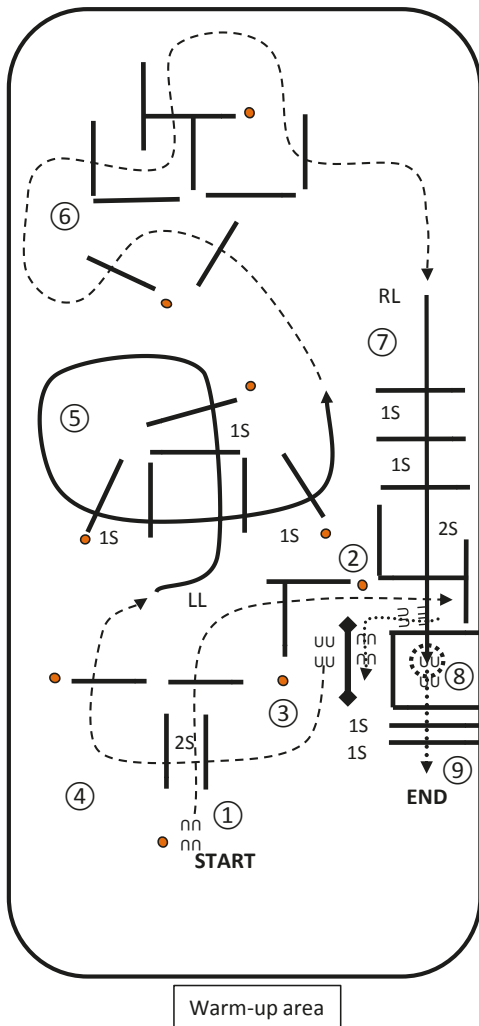

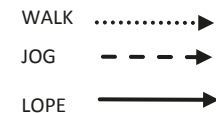

- 1 JOG OVERS PAST MARKER INTO CHUTE-STOP
 - 2 BACK L TO GATE
 - 3 LH GATE OPEN RIDE THRU CLOSE-JOG OUT
 - 4 JOG OVERS
 - 5 LL LOPE OVERS
 - 6 JOG OVERS
 - 7 RL LOPE OVERS
 - 8 LOPE IN CHUTE-STOP-WALK OVERS
- END OF PATTERN

